

SOCIAL CAPITAL: NETWORKS INSIDE ORGANIZATIONS

Analysts of intraorganizational and occupational networks examine how interpersonal social relations affect status attainment dynamics, careers, and workplace outcomes

Which **positions** in stratified systems give job-seekers access to info about better employment opportunities?

- Interaction with human capital & experience
- Relative advantages of weak & strong ties



How do **mentoring, networking, friendships** shape personal careers, work team social cohesion, and organizational productivity & performance:



Better to rely on mentors or dispersed ties?

Are weak or strong ties better? When?

Are work-friends assets and liabilities?

Do teams boost productivity and tyrannize?

Network Concepts

Any small, closed social system may be treated as a **complete network** of social relations among a set of actors (persons, groups, or organizations)

“Small” = half-dozen to a few hundred actors

Egocentric network consists of one focal actor (*ego*) and its direct ties to a set of others (*alters*), plus all the links among those alters

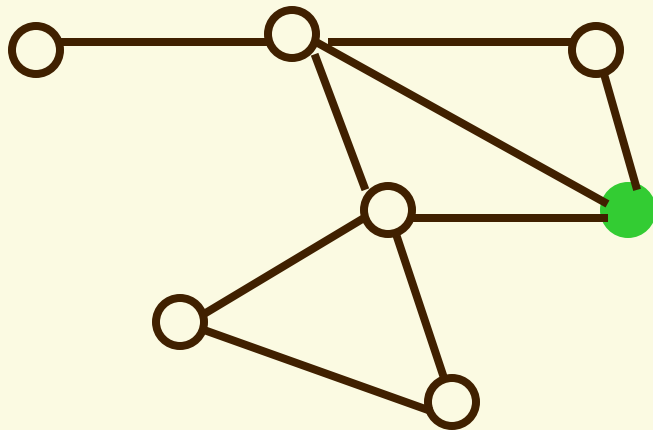

Work team – a complete network

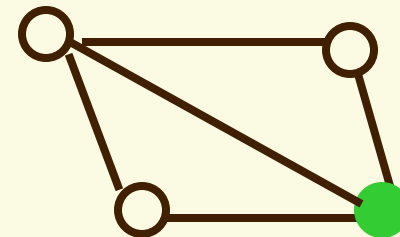

Ego net – friends of ego

Network Relational Contents

Diagramming one or more networks in a social system requires ego actors to report all the **dyadic direct ties** (pairwise linkages), of a specific type, that connect them to all other alter actors

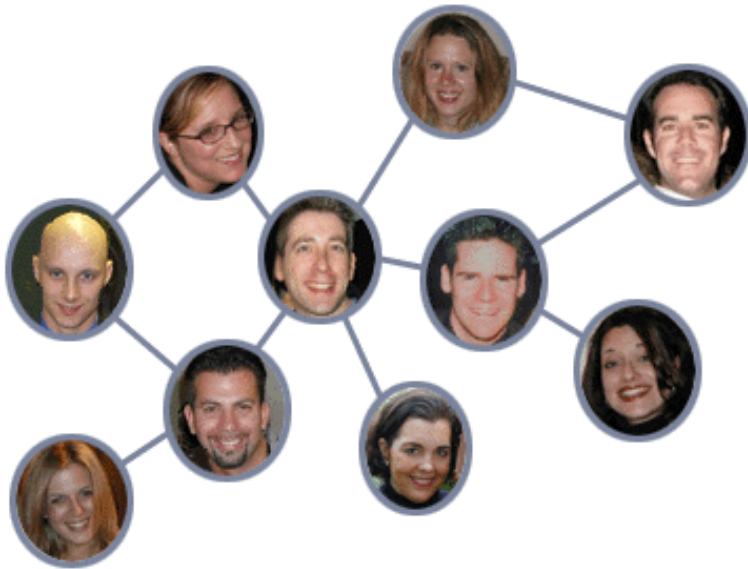

A **relation** is the set of all ties of one specific type, measured for every pair of actors (dyad) in the network

- A tie is a direct connection or interaction between a dyad
- An absent tie of a dyad can be as relevant as a present tie
- Multiple relational contents may connect a dyad (friend, advice,...)

Relational content refers to a tie's substantive meaning, the relatively homogeneous linkages connecting network actors. Varieties of contents, both positive and negative, are potentially unlimited: friendship, dislike, work with, play with, advise, distrust, consult, lend \$\$\$, house-sit, walk the dog for,

Diagram YOUR Ego Network

1. Around a circle, write your name (EGO) and as many as 5 people (ALTERS) with whom you might “discuss work-related matters”
2. Draw a line from your name to each alter. Label each line with that person’s primary relation to you: family, friend, supervisor, coworker, classmate, teacher, etc.
3. Draw lines between alters showing only their strongest tie to one another and label: kin, close friend, friend, acquaintance (no line = strangers)
4. How connected is your work-related ego-net? Are all your alters directly linked (strong clique)? Or are you the central star in your own constellation?

Varieties Of Network Centrality

Persons & groups occupy different types of **central positions** in intraorg'l communication and exchange networks, with varied implications for the types of power resources they can wield.



Central location reflects an ego's high **demand** from others (high prestige as a target of popular choices) and greater **reach** (access to information, economic & political resources).

Formal org'l structure influences which type of centrality is most useful for playing the game.

Bureaucratic hierarchies are asymmetric power/authority networks (Weber's "legitimate power") based on command-obey and report-to vertical relations of superiors and subordinates.

Betweenness centrality (brokering structural holes) is useful strategy for person seeking to be a Machiavellian "player"

Workteams are egalitarian networks based on advice & trust ties that build coworker cohesion/solidarity and boost team performance. As in dancing and horseshoes, **closeness** counts!

Which Actors Are Central? Why?

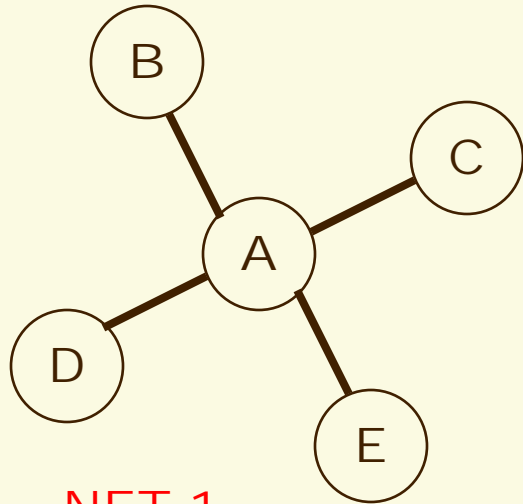

NET 1

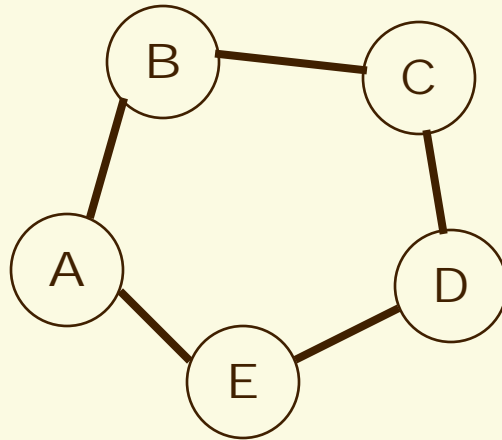

NET 2

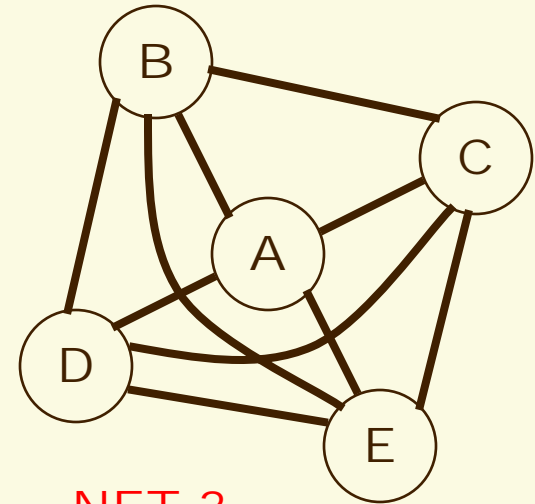

NET 3

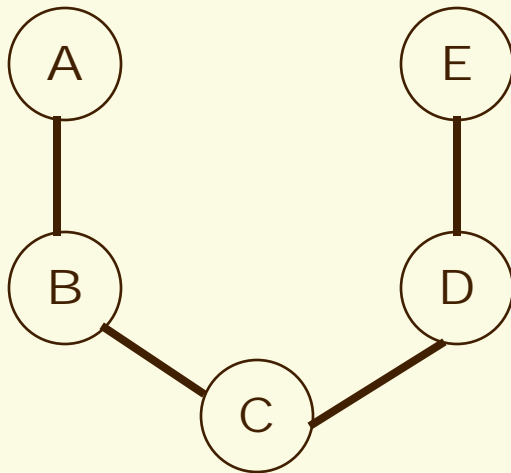

NET 4

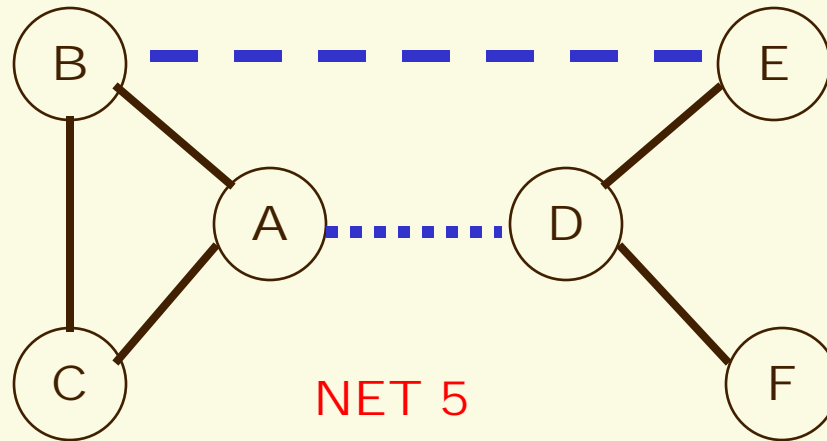

NET 5

Whom Do You Trust?

David Krackhardt & Jeffrey Hanson argue that detailed “maps” of org’s networks can help to improve morale & performance.



In Leers Computer Corp., maps of advice & trust networks revealed great differences in who were the central players.

Although many turned for Tom Harris technical advice, why was he an ineffective leader of the task force?

Why did Leers chose Bill Benson as task force co-leader?

What problem did the maps reveal about Jim Calder’s ability to lead a diverse group of design consultants?

How can network analysis deal with these common communication problems?

- Imploded relations
- Irregular communication patterns
- Fragile structures
- Holes in the network
- “Bow ties” (everyone depends on one employee)



Investing in Social Capital

Social capital consists of ego's direct & indirect connections to others who could provide important resources & emotional support. Social capital is embedded in specific relationships that are the jointly owned property of both parties.

Social capital is increasingly important for organizational careers: finding info about jobs, getting hired, good performance ratings, promotions.

Key Proposition: People and organizations with network ties that give them access to more high-quality social capital can better perform their tasks and achieve their goals.

Two basic forms of social capital:

- **Network closure with strong ties:** intense, frequent, emotional
Tight-knit teams rely on solidarity (soldiers, sailors, police, firefighters)
- **Network extension via weak ties:** infrequent, causal acquaintance
R&D scientists need to gather data from many diverse sources

Social Capital Investments

To get ahead inside a competitive organization, you should develop your networking skills for **social capital investments**



- “Profit” is generated by having high rates of return on social capital – these benefits are paid to you by your network contacts
- Your personal location within workplace networks holds the key to earning a high return on your networking investments

Become a “network player” by developing new contacts that can improve your chances of gaining two types of network benefits:

(1) Information benefits – early timing & quick access to crucial data

Create a large, diverse (non-redundant) network of trusted contacts

(2) Control benefits – manipulate your org’l network’s **structural holes**

Holes are opportunities to play one person against another

Find & fill gaps between contacts that you can exploit in negotiations

Become a broker who can connect the holes between clusters of actors

Find & Bridge Structural Holes

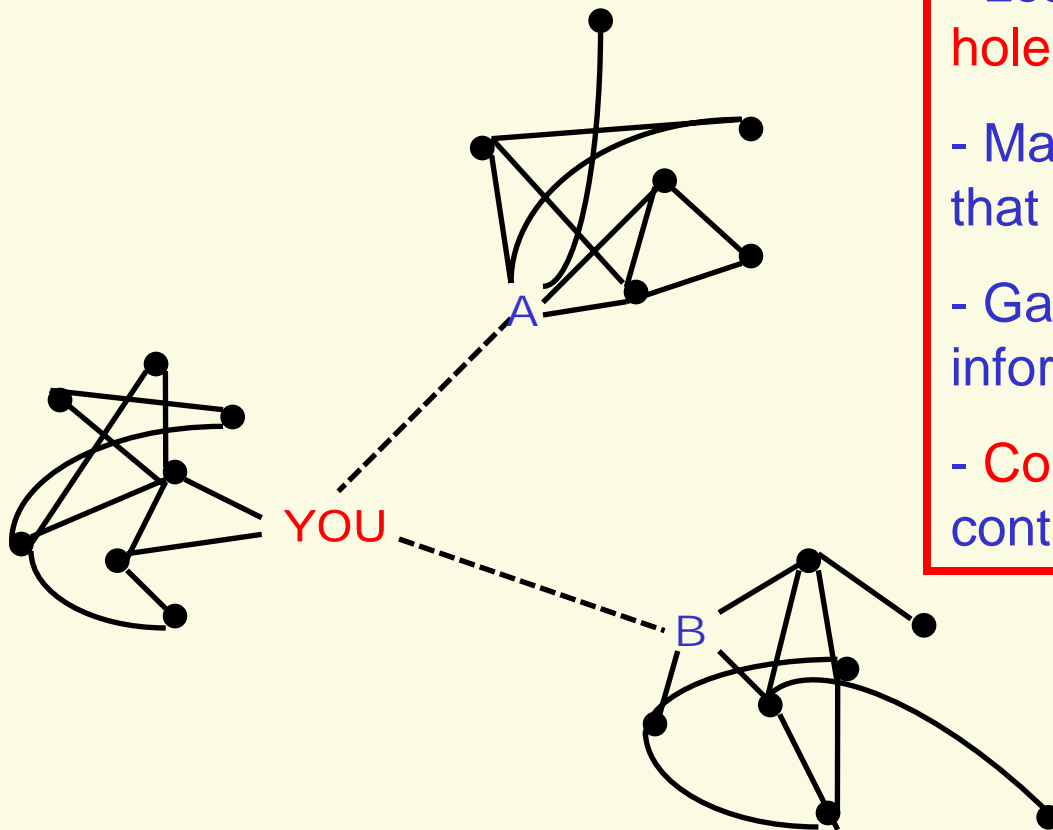

- Learn how to identify **structural holes** between network positions
- Make new network connections that **bridge** across discrete clusters
- Gain **power** by **brokering** flows of information & resource exchanges
- **Control** access among your contacts for your own **benefit**

Who Has Greater Info & Control Benefits?

Is Robert or James better able to use direct and/or short indirect ties to connect with diverse org'l subgroups? What about actors 1, 2, 5, 6, & 7?

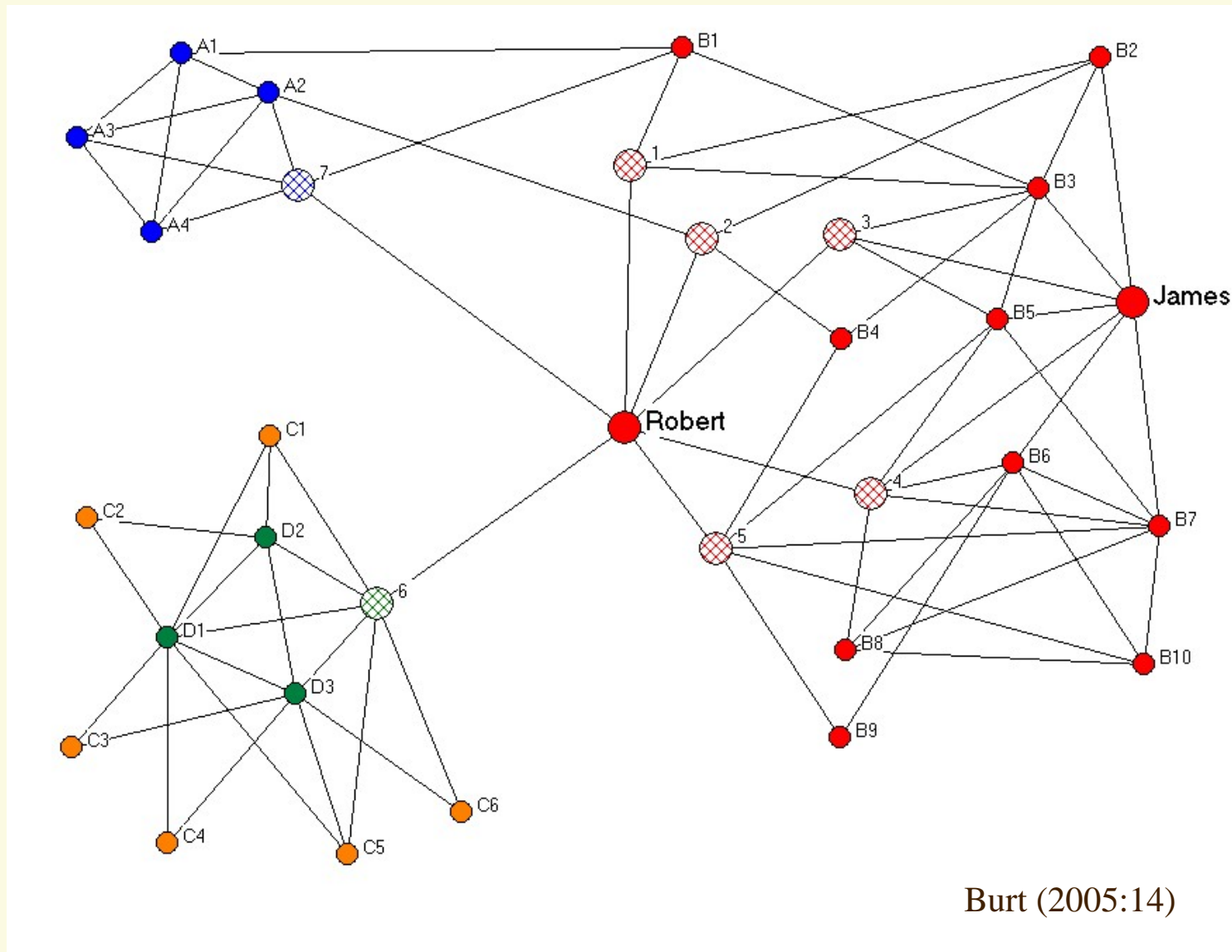

A Developmental Network Typology

Higgins & Kram (2001) reconceptualize mentoring relations as **developmental networks**. They identify and label four types of protégé-developer networks by crossing (1) the **strength** of interpersonal ties with (2) the **range** of relationship diversity:

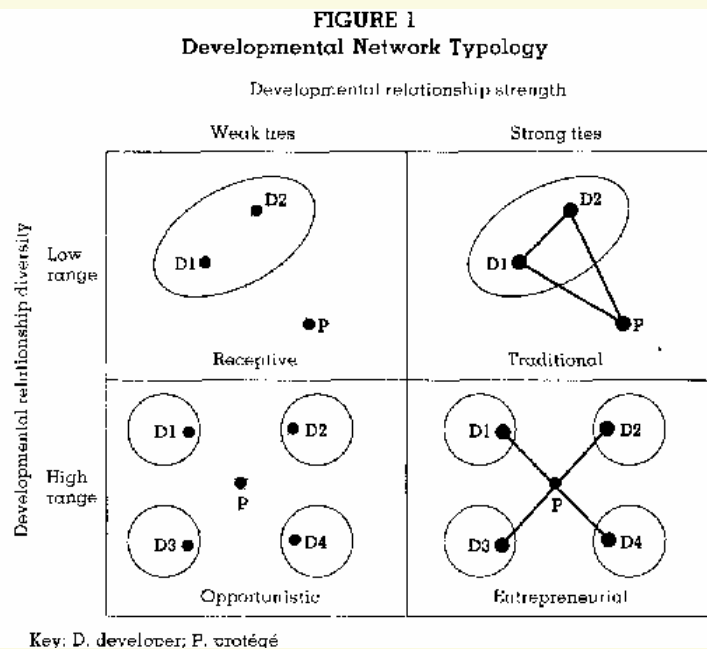

Low-range of ties creates either:

Traditional: Classic mentoring of strong tie to one developer, or a clique-structure, inside an org. Strong support, but redundant info.

Receptive: A few weak ties in the same organization. Consistent but weak support. Similar information.

Narrow ranges of both develop'1 nets results in impacted knowledge – “similar info, including similar attitudes & cognitive judgments.”

High-Range Develop'1 Nets

In contrast, if developmental nets built on high range of ties, protégés can bridge to diverse clusters of unconnected people:

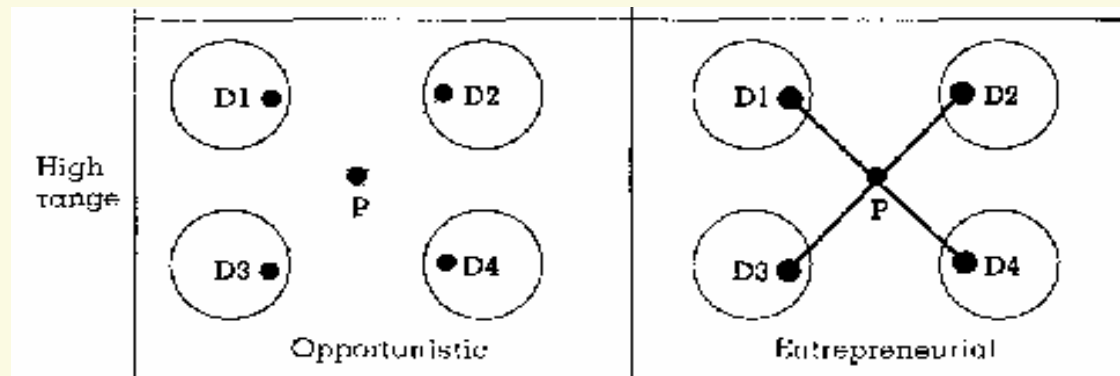

Key: D, developer; P, protégé

A high-range of ties – spanning org'l boundaries – creates:

Entrepreneurial: Many strong supporters are motivated to act on behalf of the protégé, “and who collectively provide access to a wide array of information.”

Opportunistic: The protégé generally lacks strong personal ties to developers, and takes a more “passive stance toward actively initiating and cultivating such relationships.”

Propositions on Mentoring Networks

Propositions on develop'l network effects on protégé career outcomes shape org'l workforce's mobility & professionalization:

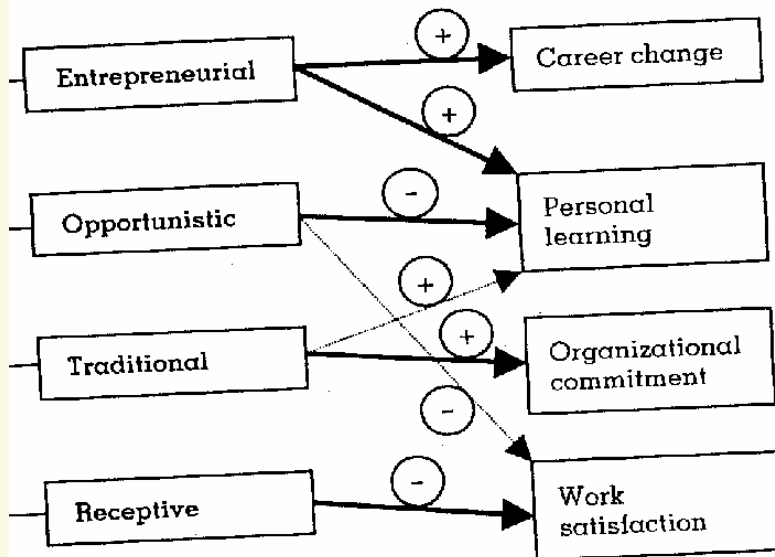

Entrepreneurial strong ties to a diverse range of developers exposes a protégé to many career opportunities, personal growth

Traditional nets tighten bonds to an employer, hard to break away

Opportunistic ties are too superficial, & **receptive** nets too weak, to be helpful – Avoid ‘em like plague!

If Higgins & Kram's developmental network propositions are correct, then how should employers encourage the creation of developer-protégé networks that would provide the most benefits for both the employees and their organizations?

Mentoring or Networking?

Watch an excerpt from *Working Girl* (1987) starring Melanie Griffith, Sigourney Weaver, and Harrison Ford. Tess McGill wants to move up the corporate ladder from secretary to manager. Her boss, Kathryn Parker, seems to be a positive role model. But, does Kathryn really look out for Tess's best interests?

This excerpt illustrates both networking and mentoring. At its end, the dramatic plot twist is a betrayal of trust. Group discussion:



Apply the Higgins & Kram developmental network typology to analyze Tess's situation.

Explain how her dependency on Kathryn left Tess structurally vulnerable to her boss's actions.

What type(s) of mentoring network would you advise Tess to develop that might be more supportive; why?

Guanxi Networks in China

“*Guanxi* generally refers to relationships or social connections based on mutual interests and benefits ... a special type of relationship that bonds the exchange parties through reciprocal exchange of favours and mutual obligations.” (Lee et al. 2001:52 quoted in Parnell 2005)



Guanxi networks are based on strong ties of blood/marital loyal relations or social identities (“classmates”). Chinese gain “face” by knowing how to act appropriately. Outsiders can enter when a mutual friend vouches.

Guanxi networks facilitate economically efficient exchanges in a fragmented, weak-rule-of-law society. They enabled China’s rapid transition from command to market economy since 1978.

Chinese culture views the *guanxi* obligation to reciprocate as ethical behavior, not as a “using” relationship. But, *guanxi*’s dark side is potential to cover-up **corrupt transactions** within relations.

Build a *Guanxi* Network in China

“The stranger, the ‘outsider’, for example, a (foreign) potential business partner, has to undergo a gradual induction process, imbibing the ‘rules of the game’, to become a member of the inner circle or its equivalent, of family and close friends. ... it may be short-circuited by employing an intermediary with ‘face’ ... but success is not guaranteed.” (p. 31)



Your organization, MINN-Widgets, wants to enter the lucrative Chinese market for widgets, but must find business partners from both the private and the state-owned sectors.

Small groups discuss how to build a lasting *guanxi* network:

- ✓ What kinds of go-betweens/brokers should you seek?
- ✓ Who has technical and culture knowledge useful to M-W?
- ✓ How could you get their help, support, protection without losing “face” in this politically sensitive environment?

References

Burt, Ronald S. 1992. *Structural Holes: The Social Structure of Competition*. Cambridge MA: Harvard University Press.

Burt, Ronald S. 2005. *Brokerage & Closure: An Introduction to Social Capital*. Oxford, UK: Oxford University Press.

Parnell, Martin F. 2005. "Chinese Business *Guanxi*: An Organization or Non-organization?" *Journal of Organisational Transformation & Social Change* 2:29-47.

Higgins, Monica C. and Kathy E. Kram. 2001. "Reconceptualizing Mentoring at Work: A Developmental Network Perspective." *Academy of Management Review* 26:264-288.

Krackhardt, David and Jeffrey R. Hanson. 1993. "Informal Networks: The Company Behind the Chart." *Harvard Business Review* (July-August):104-111.